

目錄 MAPX	變更內容 MODIFICATION	日期 DATE
------------	----------------------	------------

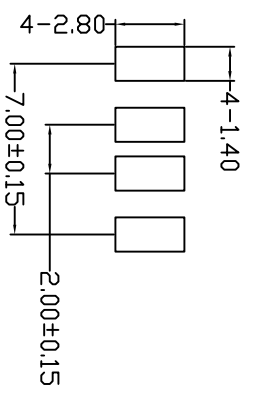
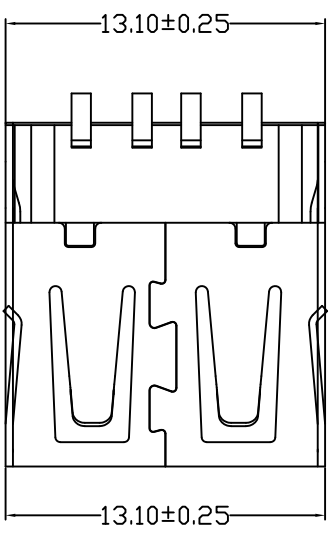
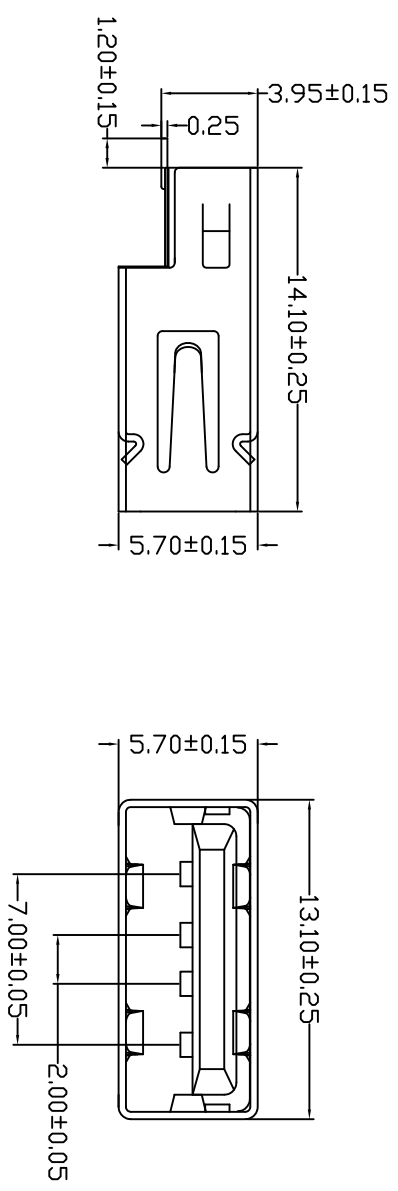

RECOMMENDED P.C.B LAYOUT

- Material:
Contacts: PHOSPHOR BRONZE T=0.25MM
Insulator: LCP+30% G.F. UL 94V-0, BLACK
Shell: C2680 -H /SPPC T=0.30MM
- Mechanical:
Mating: 35N max.
Withdrawal Force: 10N min.
Durability: 1500 cycles min.
- Electrical:
Current-max(amps):1.5A
Voltage-max(volts):30V
withstanding Voltage: 500V AC
Contact Resistance (ohms): 30 milliohms max
Insulation Resistance (ohms): 1000 Megohms min
- Plating:
Contacts: Gold 1u" min plated ON MATING AREA, Sn
120u"min PLATED ON SOLDERING, 50U" NICKEL UNDER
PLATING OVERALL
SHELL: Nickel 60u"Min Over All Plating
- Environmental
Temperature Range: -55°~+85°C

备注: 侧弹分为外弹与内弹

产品图
PRODUCT CHART DWG

深圳市精拓金电子有限公司

公差一览表 TOLERANCE UNLESS OTHERWISE		单位 UNITS	MM	制图 DRAWING	Z-Y-B	产品料号 PRODUCT PART NO.	
X	±0.25	X'	±5'	审核 CHECK	雷永键	产品名称 PRODUCT NAME	USB-AF沉板无边内弹 (SMT)
.X	±0.20	.X'	±2'	核准 APPD	雷永键	角法 VIEW	⊕ ⊖
.XX	±0.15	.XX'	±1'	日期 DATE	2014.06.03	版本 VER	A0
.XXX	±0.10	.XXX'	±0.5'				