

Features

- Uses CRM(CQ) advanced SkyMOS2 technology
- Extremely low on-resistance $R_{DS(on)}$
- Excellent $Q_g \times R_{DS(on)}$ product(FOM)
- Qualified according to JEDEC criteria

Applications

- Synchronous Rectification for AC/DC Quick Charger
- Battery management
- UPS (Uninterruptible Power Supplies)

Product Summary

V_{DS}	100V
$R_{DS(on)@10V}$ typ	7.2mΩ
$R_{DS(on)@4.5V}$ typ	9mΩ
I_D	78A

100% Avalanche Tested

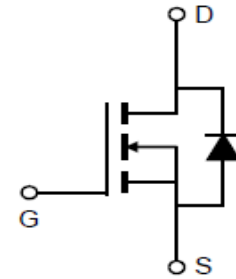
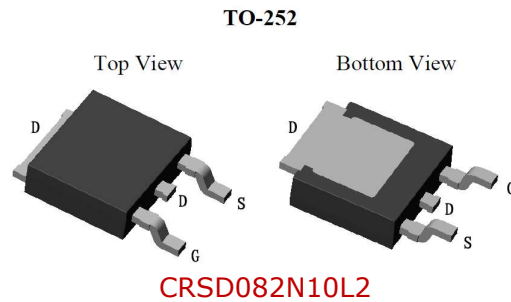
Package Marking and Ordering Information

Part #	Marking	Package	Packing	Reel Size	Tape Width	Qty
CRSD082N10L2	-	TO-252	Tape&Reel	N/A	N/A	2500pcs

Absolute Maximum Ratings

Parameter	Symbol	Value	Unit
Drain-source voltage	V_{DS}	100	V
Continuous drain current $T_C = 25^\circ\text{C}$ (Silicon limit) $T_C = 25^\circ\text{C}$ (Package limit) $T_C = 100^\circ\text{C}$ (Silicon limit)	I_D	78 80 50	A
Pulsed drain current ($T_C = 25^\circ\text{C}$, t_p limited by T_{jmax})	$I_{D\ pulse}$	313	A
Avalanche energy, single pulse ($L=0.5\text{mH}$, $R_g=25\Omega$)	E_{AS}	121	mJ
Gate-Source voltage	V_{GS}	± 20	V
Power dissipation ($T_C = 25^\circ\text{C}$)	P_{tot}	101	W
Operating junction and storage temperature	T_j, T_{stg}	-55...+150	$^\circ\text{C}$

Thermal Resistance

Parameter	Symbol	Max	Unit
Thermal resistance, junction – case.	R_{thJC}	1.24	°C/W
Thermal resistance, junction – ambient(min. footprint)	R_{thJA}	93.8	

Electrical Characteristic (at $T_j = 25\text{ }^\circ\text{C}$, unless otherwise specified)

Parameter	Symbol	Value			Unit	Test Condition
		min.	typ.	max.		

Static Characteristic

Drain-source breakdown voltage	BV_{DSS}	100	115	-	V	$V_{GS}=0V, I_D=250\mu A$
Gate threshold voltage	$V_{GS(th)}$	1.4	1.8	2.2	V	$V_{DS}=V_{GS}, I_D=250\mu A$
Zero gate voltage drain current	I_{DSS}	-	-	1	μA	$V_{DS}=80V, V_{GS}=0V$ $T_j=25^\circ C$ $T_j=125^\circ C$
Gate-source leakage current	I_{GSS}	-	-	± 100	nA	$V_{GS}=\pm 20V, V_{DS}=0V$
Drain-source on-state resistance	$R_{DS(on)}$	-	7.2	8.6	mΩ	$V_{GS}=10V, I_D=50A$
		-	9.0	10.8	mΩ	$V_{GS}=4.5V, I_D=50A$
Transconductance	g_{fs}	-	91	-	S	$V_{DS}=5V, I_D=50A$

Dynamic Characteristic

Input Capacitance	C_{iss}	-	2626	-	pF	$V_{GS}=0V, V_{DS}=50V,$ $f=1MHz$
Output Capacitance	C_{oss}	-	457	-		
Reverse Transfer Capacitance	C_{rss}	-	38	-		
Gate Total Charge	Q_G	-	44.5	-	nC	$V_{GS}=10V, V_{DS}=50V,$ $I_D=50A, f=1MHz$
Gate-Source charge	Q_{gs}	-	10.4	-		
Gate-Drain charge	Q_{gd}	-	6.8	-		
Turn-on delay time	$t_{d(on)}$	-	10.3	-	ns	$V_{GS}=10V, V_{DD}=50V,$ $R_{G_ext}=3.0\Omega$
Rise time	t_r	-	62	-		
Turn-off delay time	$t_{d(off)}$	-	30	-		
Fall time	t_f	-	98	-		
Gate resistance	R_G	-	1.1	-	Ω	$V_{GS}=0V, V_{DS}=0V,$ $f=1MHz$

Body Diode Characteristic

Parameter	Symbol	Value			Unit	Test Condition
		min.	typ.	max.		
Body Diode Forward Voltage	V_{SD}	-	0.93	1.4	V	$V_{GS}=0V, I_{SD}=50A$
Body Diode Reverse Recovery Time	t_{rr}	-	64	-	ns	$I_F=50A,$ $dI/dt=100A/\mu s$
Body Diode Reverse Recovery Charge	Q_{rr}	-	101	-	nC	

Typical Performance Characteristics

Fig 1: Output Characteristics

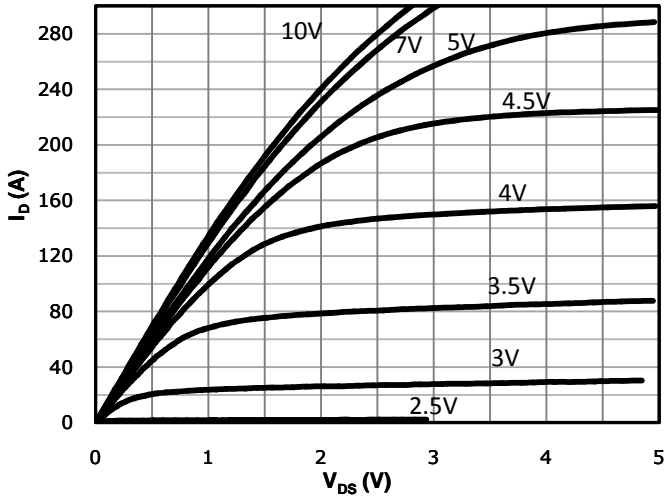
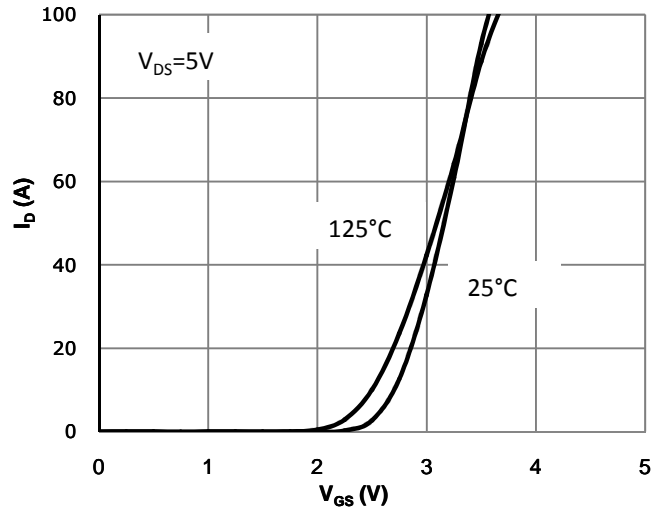

Fig 2: Transfer Characteristics



3: $R_{DS(on)}$ vs Drain Current and Gate Voltage

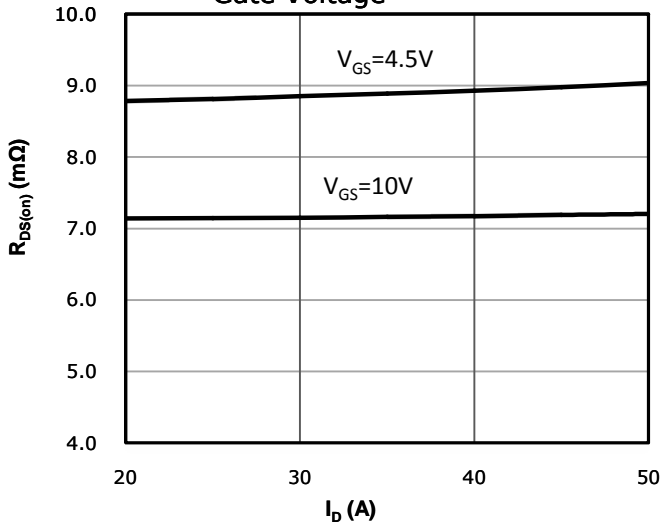

Fig 4: $R_{DS(on)}$ vs Gate Voltage

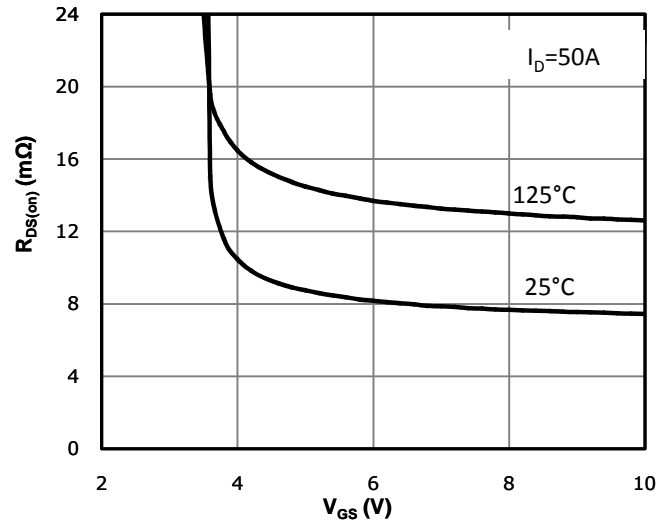

Fig 5: $R_{DS(on)}$ vs. Temperature

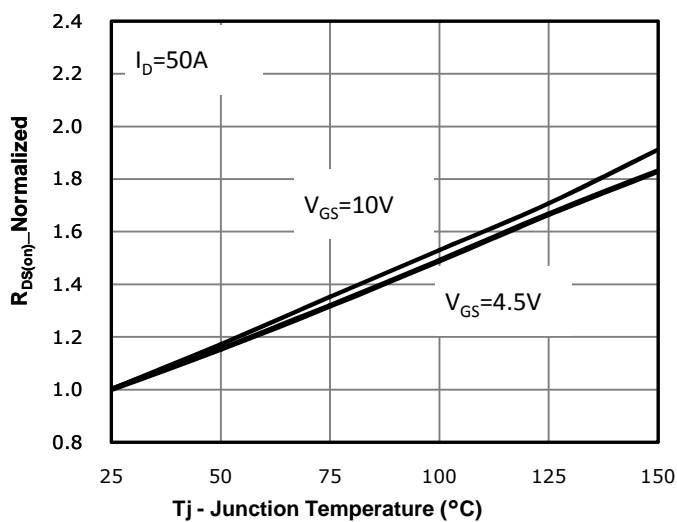

Fig 6: Capacitance Characteristics

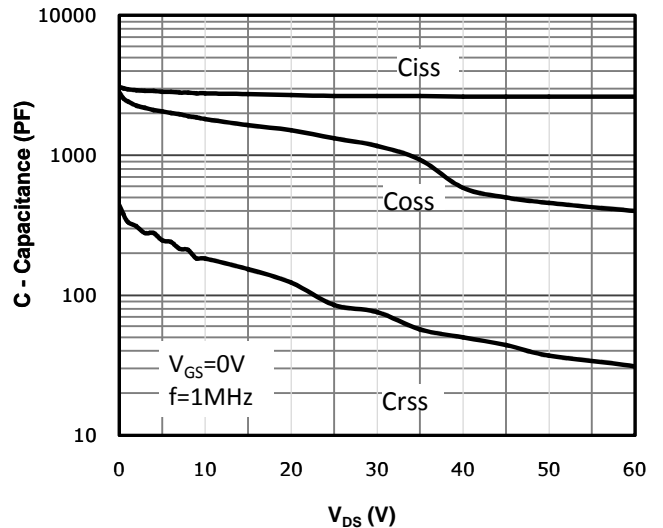

Fig 7: Gate Charge Characteristics

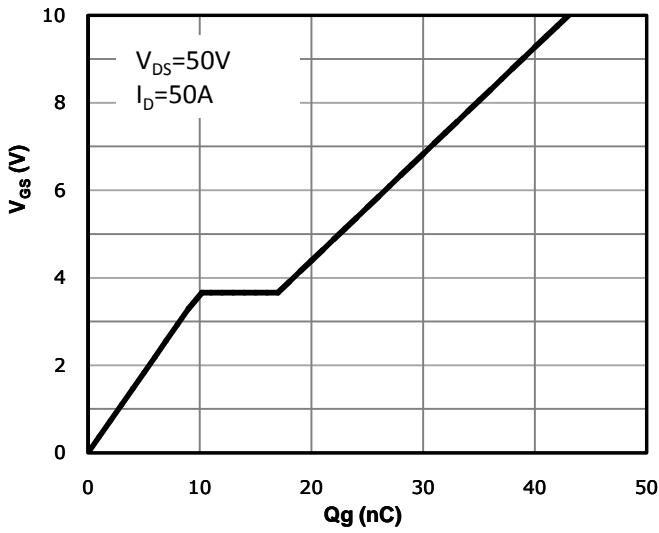

Fig 8: Body-diode Forward Characteristics

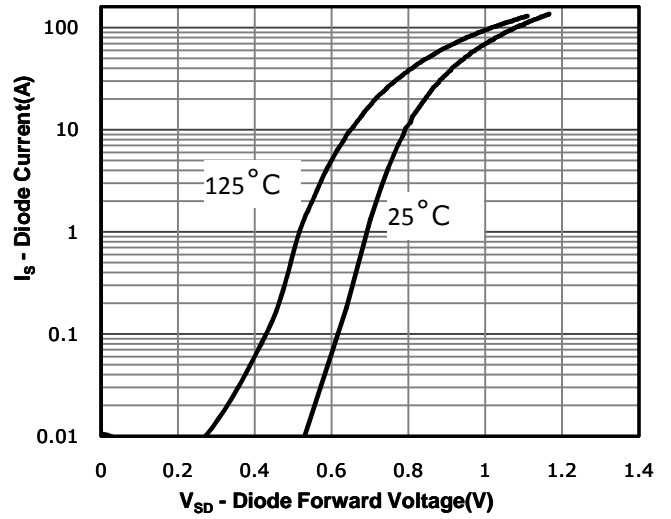

Fig 9: Power Dissipation

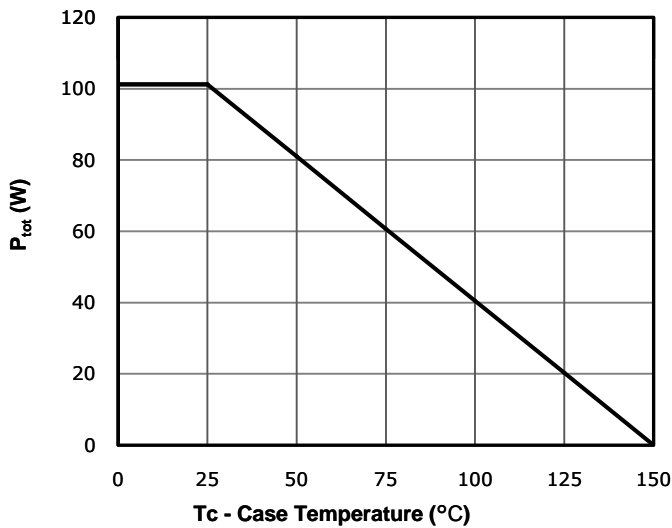

Fig 10: Drain Current Derating

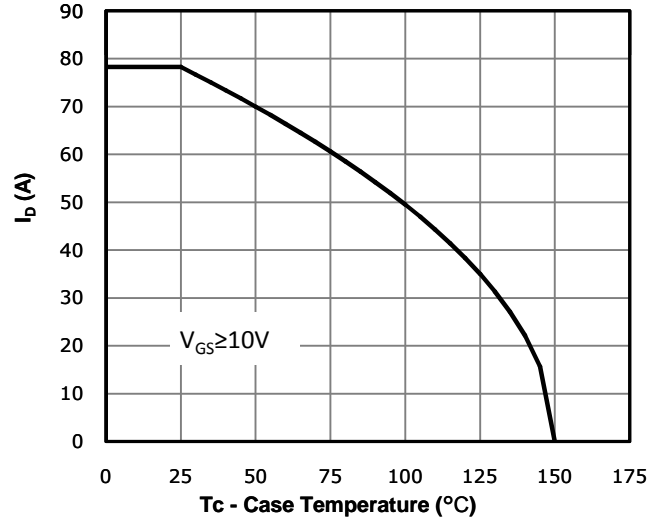

Fig 11: Safe Operating Area

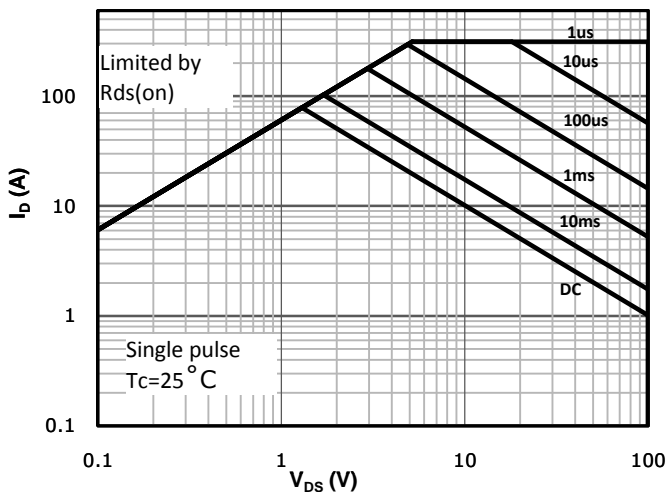
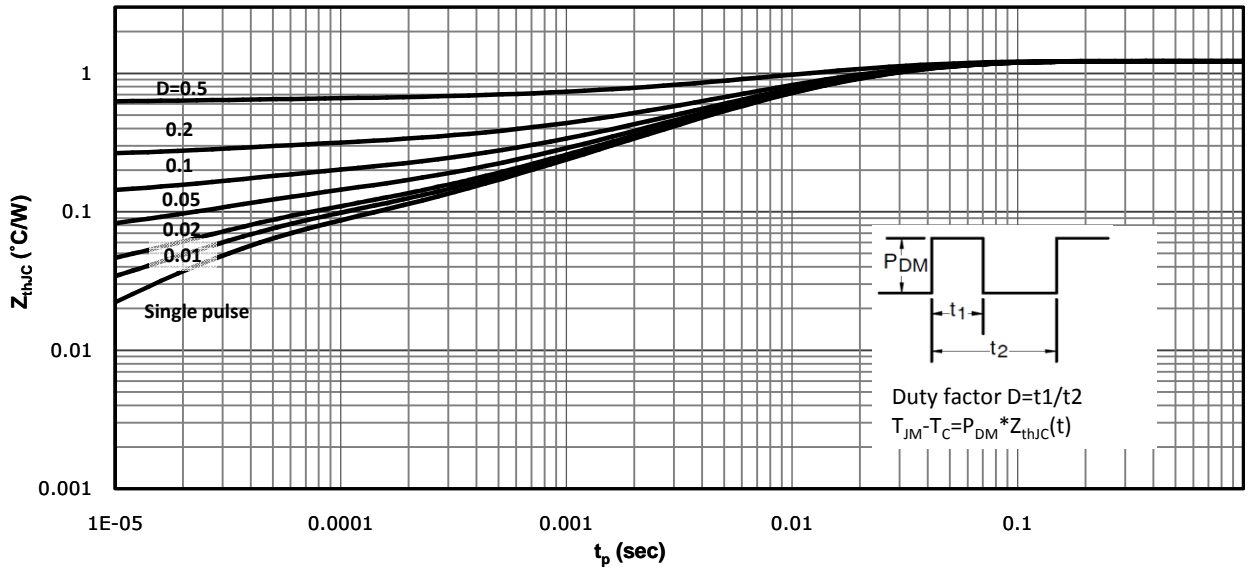
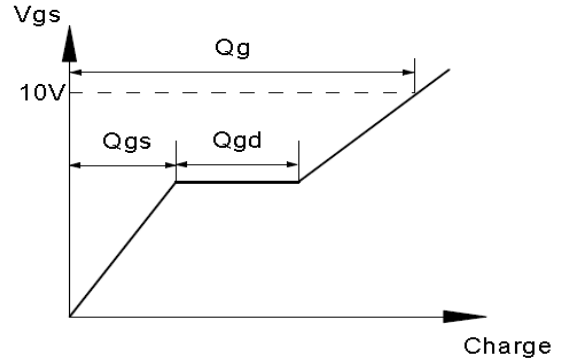
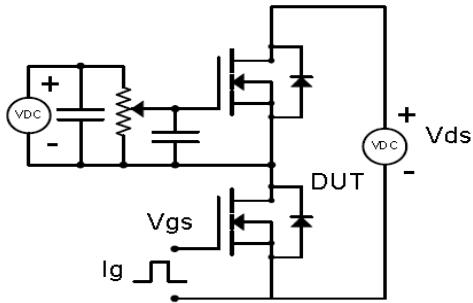

Fig 12: Max. Transient Thermal Impedance



Test Circuit & Waveform

Gate Charge Test Circuit & Waveform



Resistive Switching Test Circuit & Waveforms

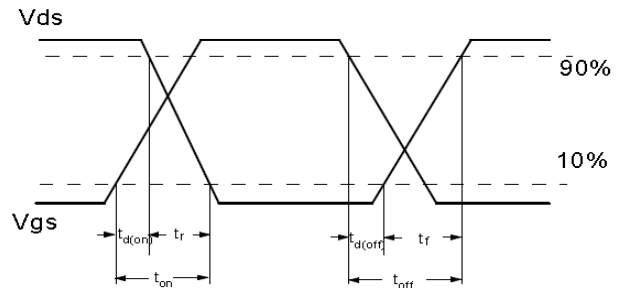
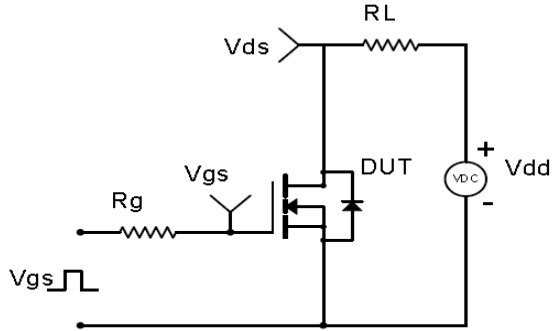

Unclamped Inductive Switching (UIS) Test Circuit & Waveforms

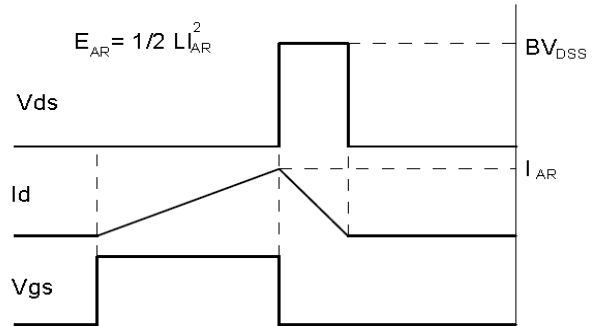
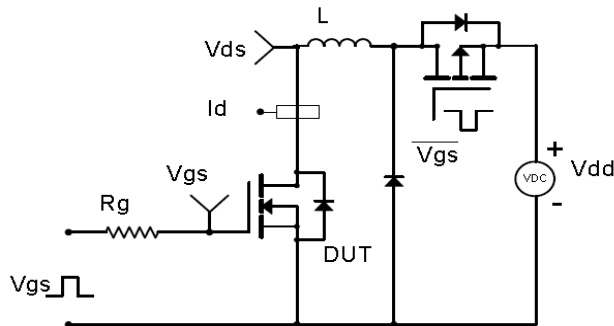

Diode Recovery Test Circuit & Waveforms

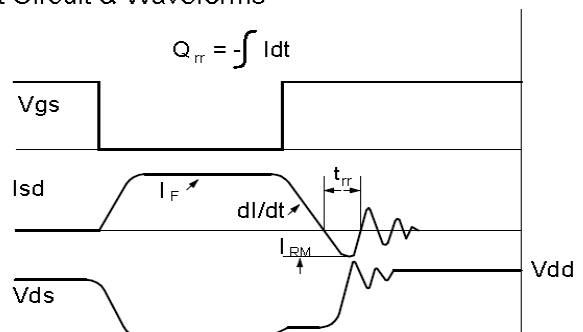
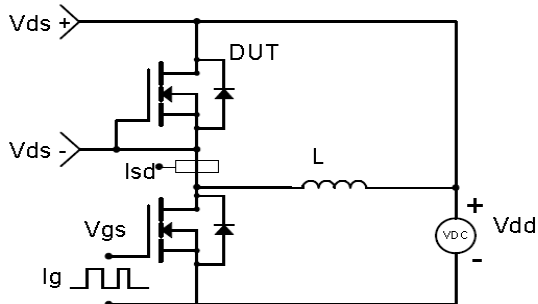

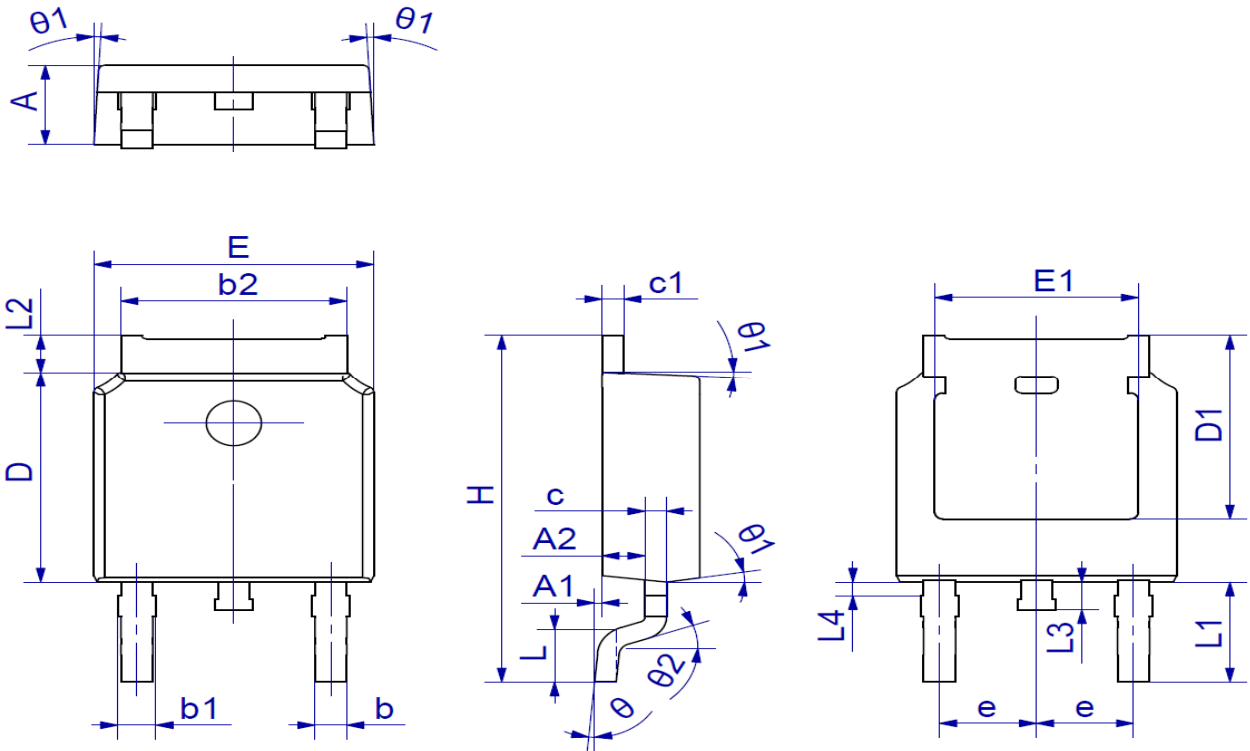
Package Outline: TO-252-3L

Symbol	Dimensions In Millimeters		Dimensions In Inches	
	Min.	Max.	Min.	Max.
A	2	2.6	0.079	0.102
A1	0	0.15	0.000	0.006
A2	0.76	1.36	0.030	0.054
b	0.61	0.85	0.024	0.033
b1	0.71	0.91	0.028	0.036
b2	5.04	5.64	0.198	0.222
c	0.508 TYP.		0.02 TYP.	
c1	0.508 TYP.		0.02 TYP.	
D	5.7	6.3	0.224	0.248
D1	5	5.6	0.197	0.220
E	6.3	6.9	0.248	0.272
E1	4.55	5.15	0.179	0.203
e	2.286 TYP.		0.09 TYP.	
H	9.65	10.4	0.380	0.409
L	1.4	1.7	0.055	0.067
L1	2.90 REF.		0.114 REF.	
L2	0.75	1.35	0.030	0.053
L3	0.6	1.2	0.024	0.047
θ	0°	10°	0°	10°
θ1	5°	9°	5°	9°
θ2	25° REF.		25° REF.	

Revision History

Revision	Date	Major changes
1.0	2018-08-14	Release of formal version.

Disclaimer

Unless otherwise specified in the datasheet, the product is designed and qualified as a standard commercial product and is not intended for use in applications that require extraordinary levels of quality and reliability, such as automotive, aviation/aerospace and life-support devices or systems.

Any and all semiconductor products have certain probability to fail or malfunction, which may result in personal injury, death or property damage. Customer are solely responsible for providing adequate safe measures when design their systems.

CRM(CQ) reserves the right to improve product design, function and reliability without notice.